

5 Axis CNC Breakout Board

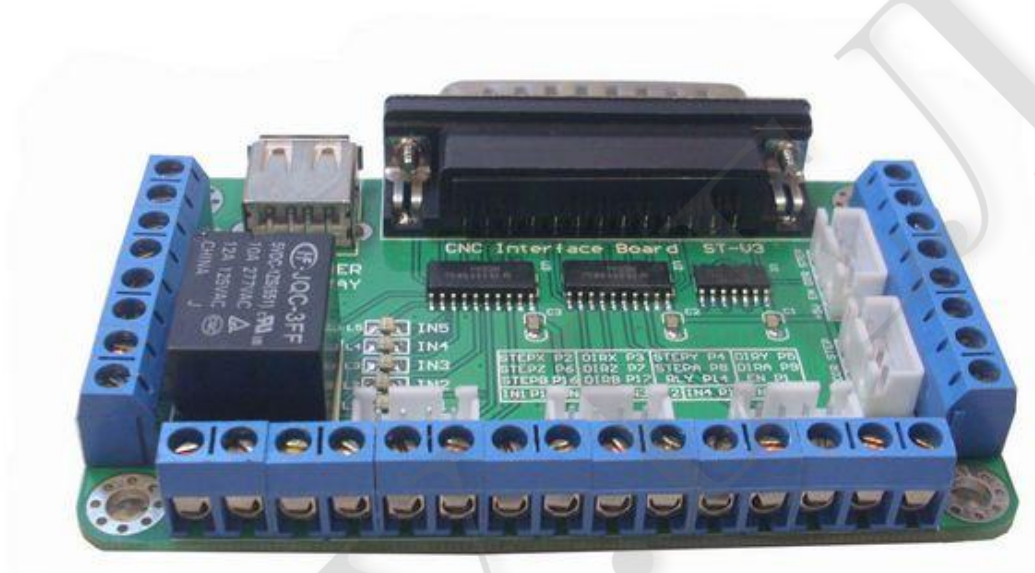

content

I 、 Features:	3
II 、 Detail:	4
III、 Definition on pins of parallel port:	5
IV. Interface Terminal Description	6
V 、 Usage of MACH3	7
1、 Startup Mach3	7
3、 Adjusting limits witch of mach3	9
4、 Running of G code	10
5、 How to use the manual control interface of MACH3	12

I 、 Features:

- ◆ full support for MACH3, KCAM4, EMC2, and support parallel port to control the host computer software;
- ◆ 5 output signal , can connect 5 stepper motor driver ;
- ◆ 5 input port, Can connect to the limit switch, emergency stop, or other Input devices , 5 input signal indication LED;
- ◆ One relay, it can be used to control spindle start and stop, 1 signal indication LED beside relay;
- ◆ power supply have 2 choice, USB power form computer or an external 5V power supply;
- ◆ pulse and direction signal shaping、 enhanced, data transfer speeds reach 10 MBit / S;
- ◆ have 2 kinds connector , the 4PIN XH connector can connect driver convenient and efficient 。

II、Detail:

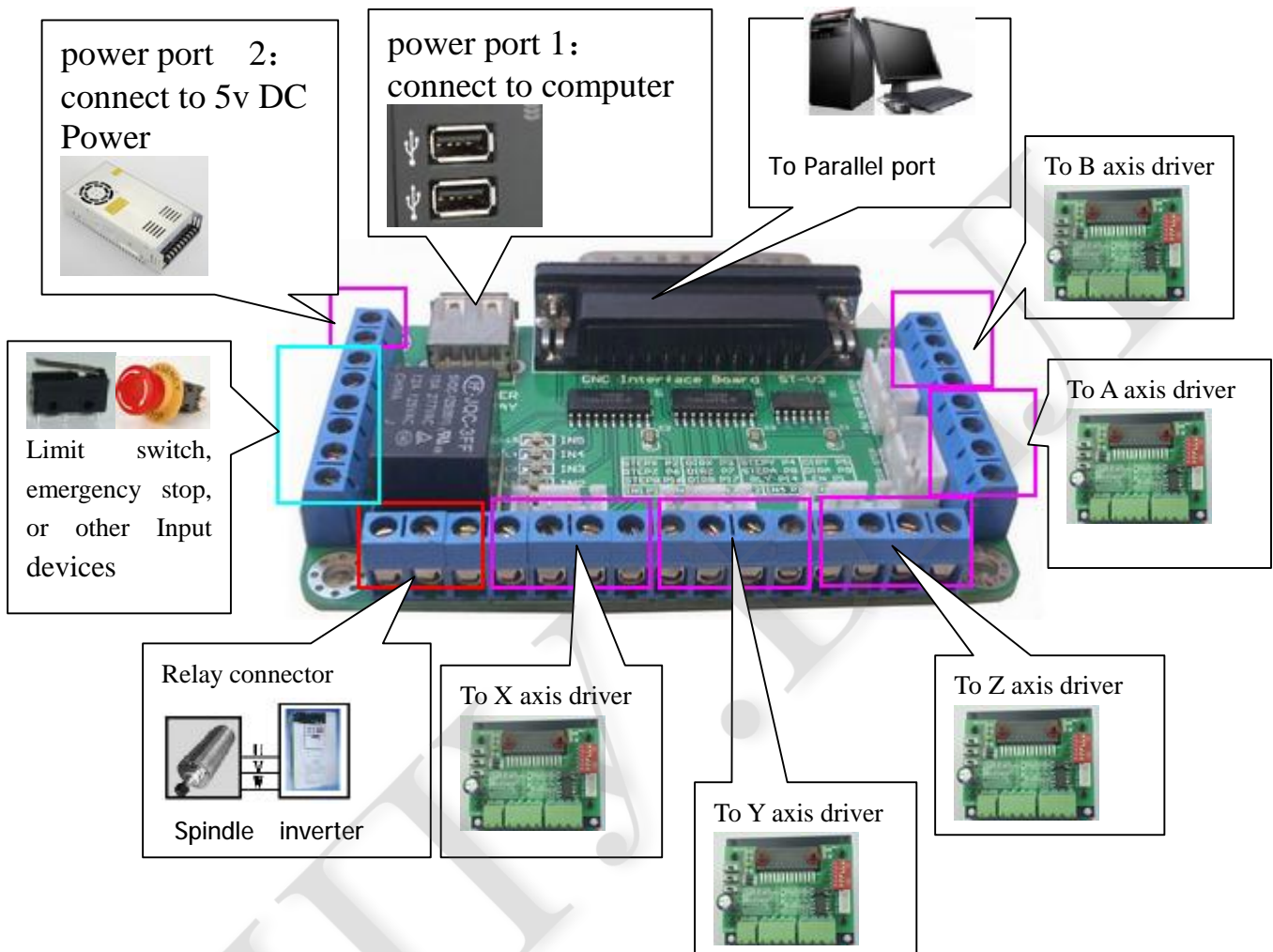

Note: power port 1 and power port 2, Can only choose one, cannot be used at the same time !

III、 Definition on pins of parallel port:

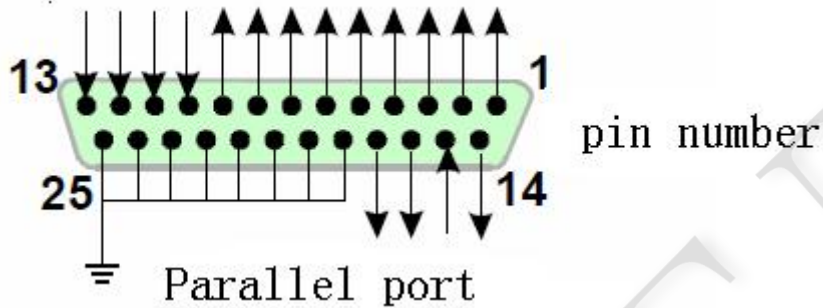

DB25(PIN)	The role of the pin on breakout board	Notes
1	EN	Enable all axis
2	STEPX	X axis pulse signal
3	DIRX	X axis direction signal
4	STEPY	Y axis pulse signal
5	DIRY	Y axis direction signal
6	STEPZ	Z axis pulse signal
7	DIRZ	Z axis direction signal
8	STEPA	A axis pulse signal
9	DIRA	A axis direction signal
10	INPUT-1	X axis Limit
11	INPUT-2	Y axis Limit
12	INPUT-3	Z axis Limit
13	INPUT-4	Emergency stop
14	Relay control	
15	INPUT-5	Input 5
16	STEPB-	B axis pulse signal
17	DIRB-	B axis direction signal
18-25	GND	

IV. Interface Terminal Description

Name	Explain	Remarks
Parallel port	the computer DB25 pin connector	With the computer communication interface
USB port	the computer USB port	Power supply for breakout board
+5V	An external power +5 V input interface	
GND	power ground	
IN5	External signal input	Light signal input
IN4	External signal input	Light signal input
IN3	External signal input	Light signal input
IN2	External signal input	Light signal input
IN1	External signal input	Light signal input
NO	Normally open relay contact	When the parallel port P14 is low, this pin is connected with COM
COM	Relay common port	
NC	Relay normally closed contact	When the parallel port P14 is low this pin is not connected with COM
+5V	+5V output pin	Access drive signal input + 5V
EN	Enable output pin	Enable effective hair pulse motor to be able to respond to
DIR	Direction signal output	
STEP	Pulse signal output	

V、 Usage of MACH3

1、 Startup Mach3

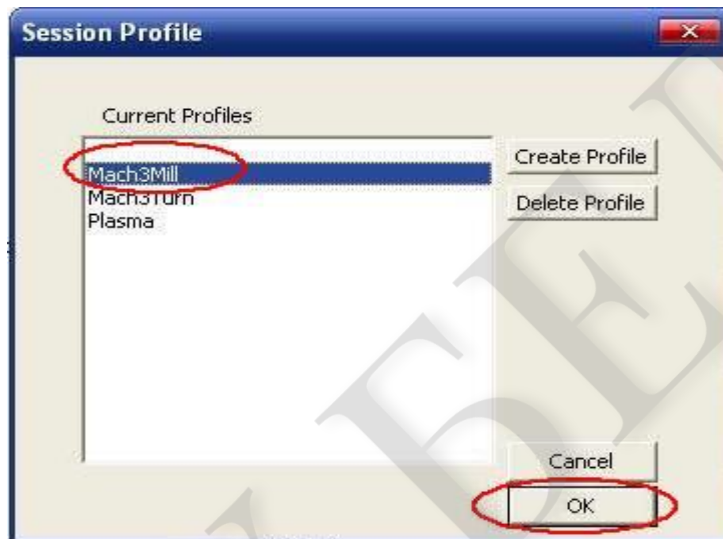

open mach3

When you have installed the software, here are 3 icons on the desk,let's click the march3Mill, as fig 11.

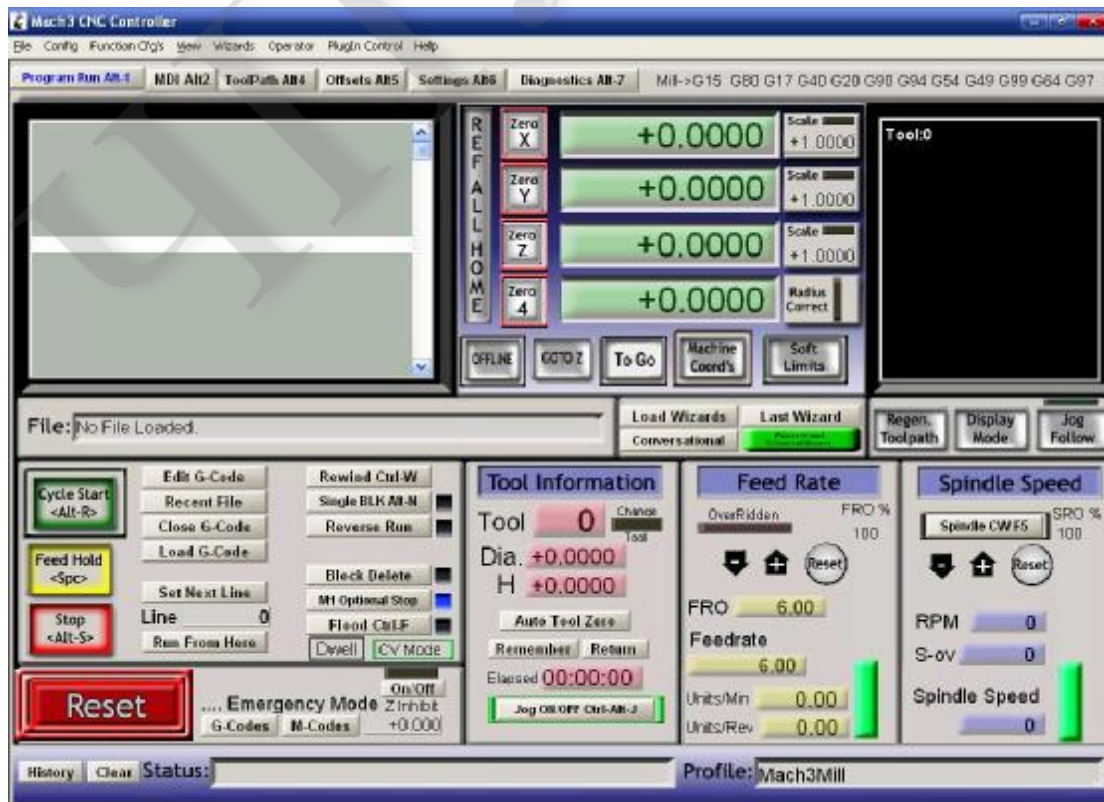

the main interface of mach3

The main interface of MACH3 as fig 12 , some basic buttons on it,Here, we first configure MACH3.

2、 The basic set of mach3

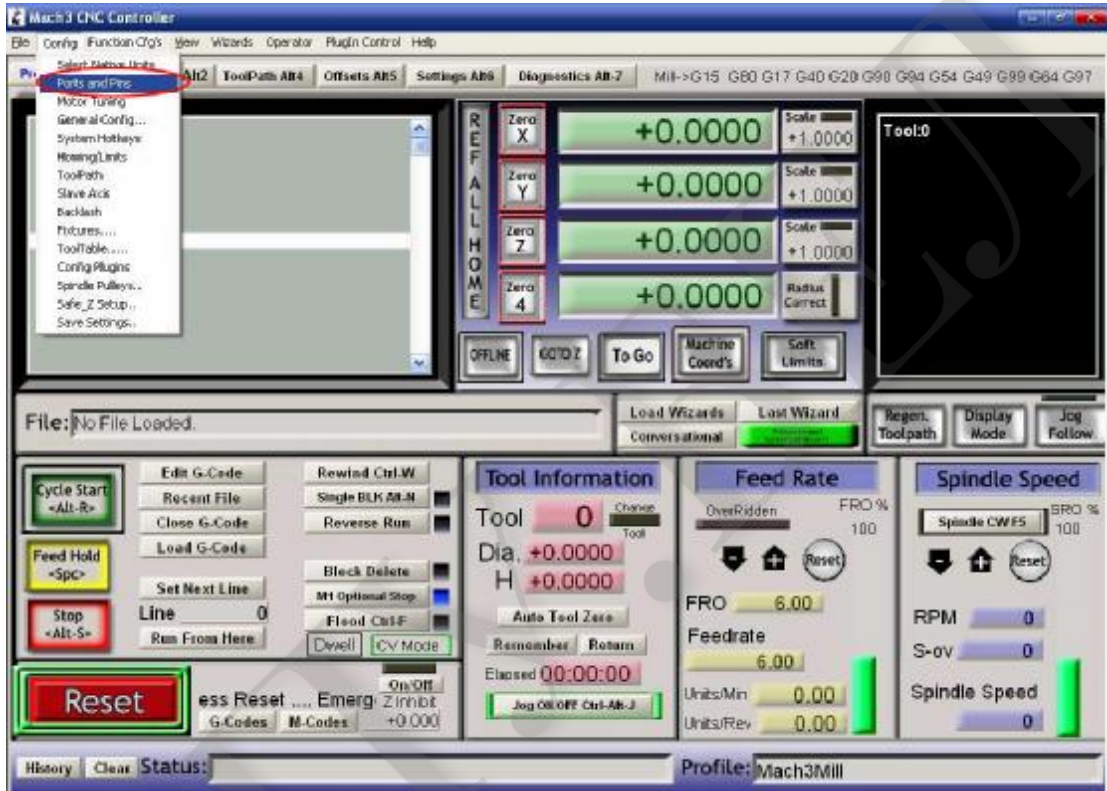

set menu of mach3

Open the config menu, ports and pins menu, marked with red circlet

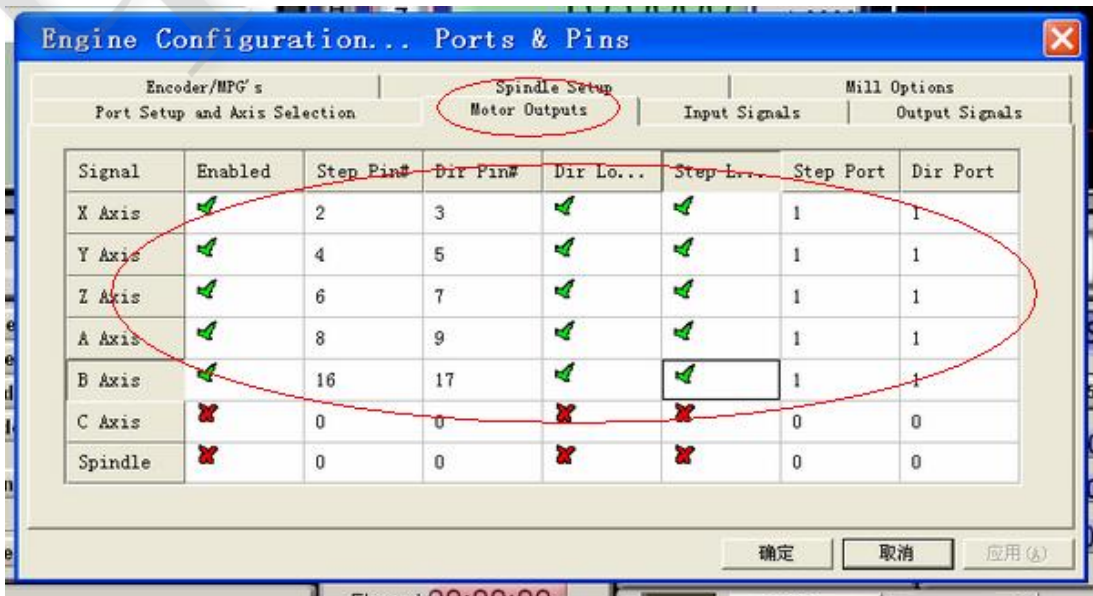

basic setting of direction and pulse pins

When you finished the setting, click output signals then set ENABLE and Relay

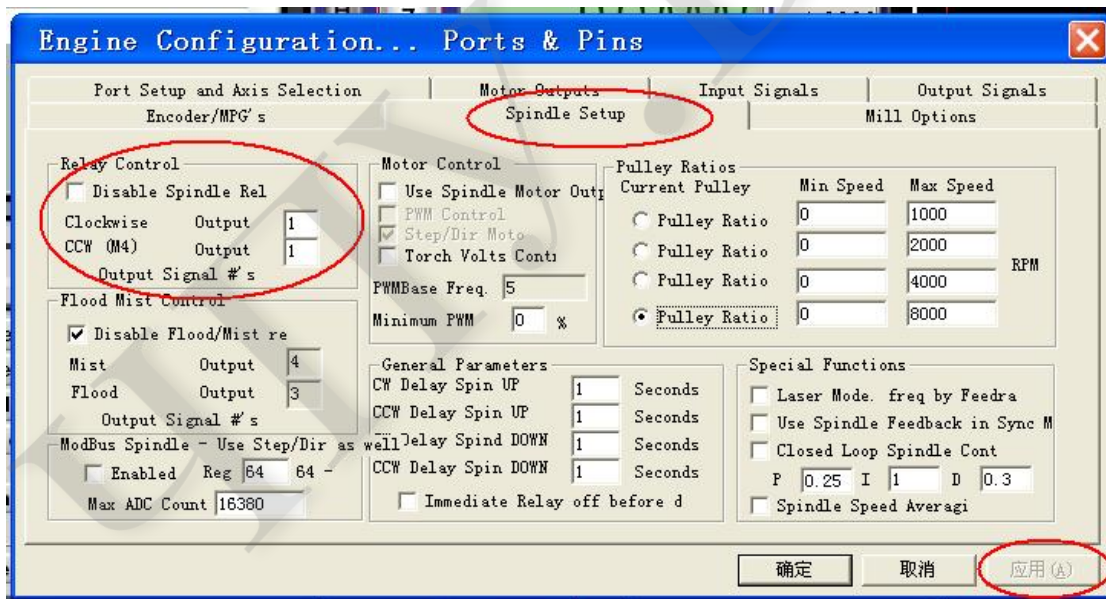
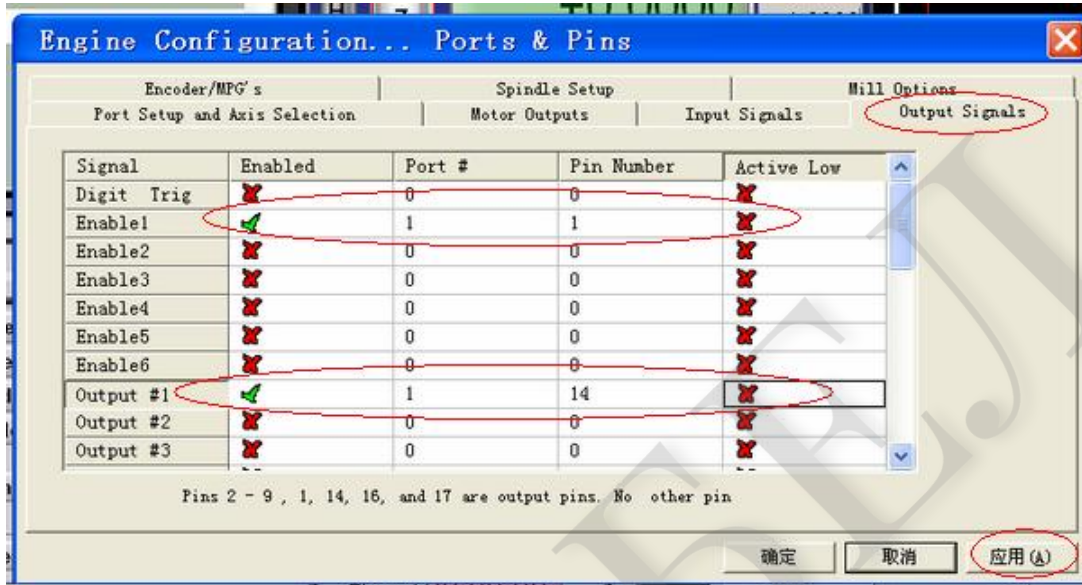

setting the ENABLE and Relay's pin

3. Adjusting limits witch of mach3

Click *input signal*, the parameter as fig17

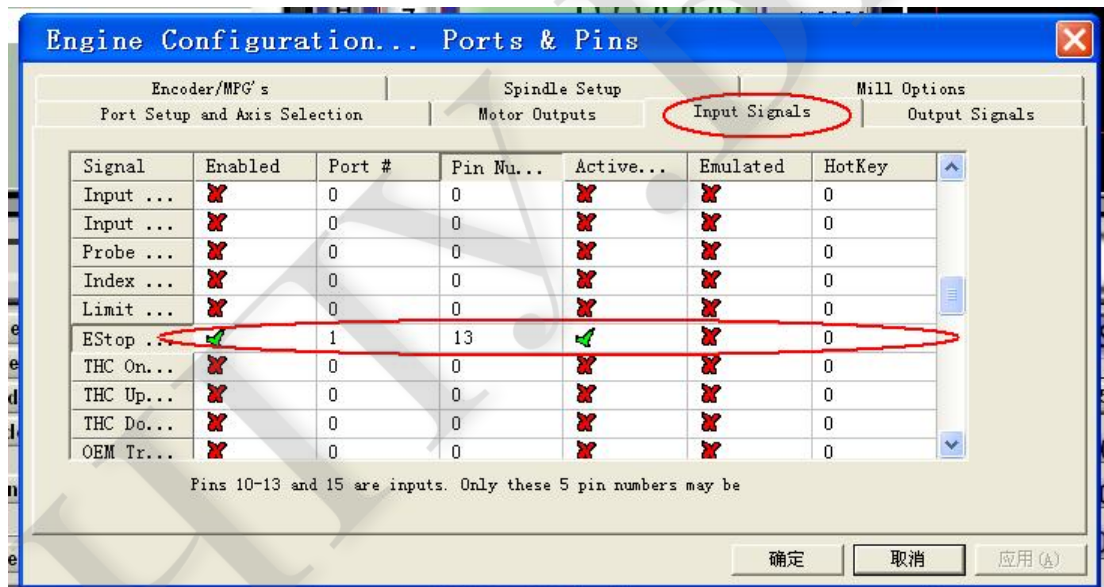
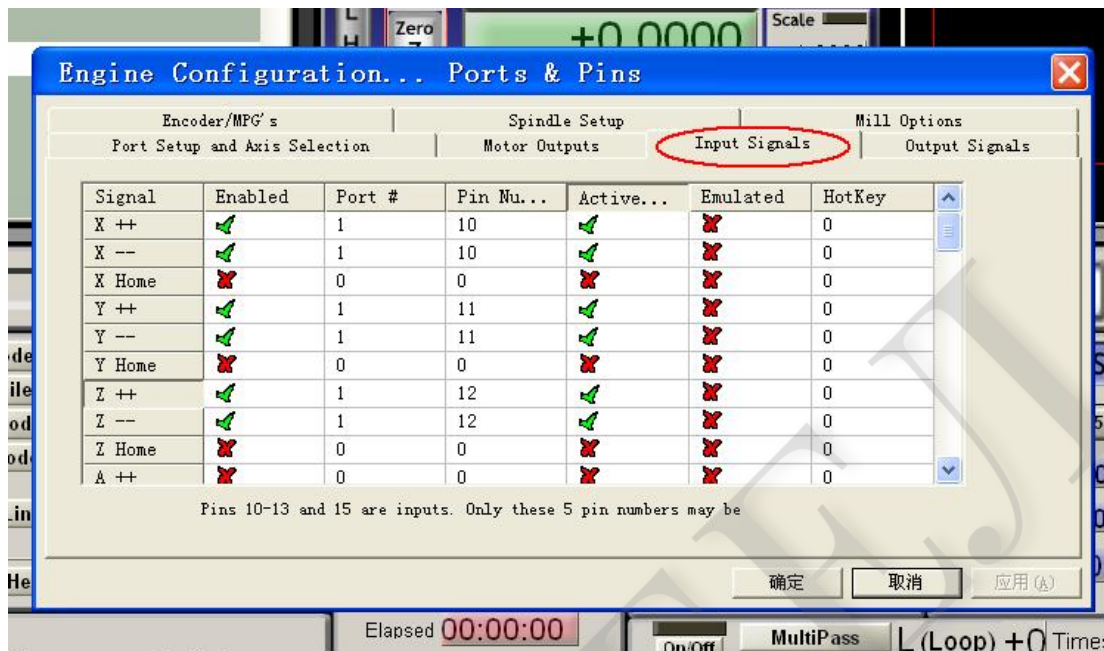

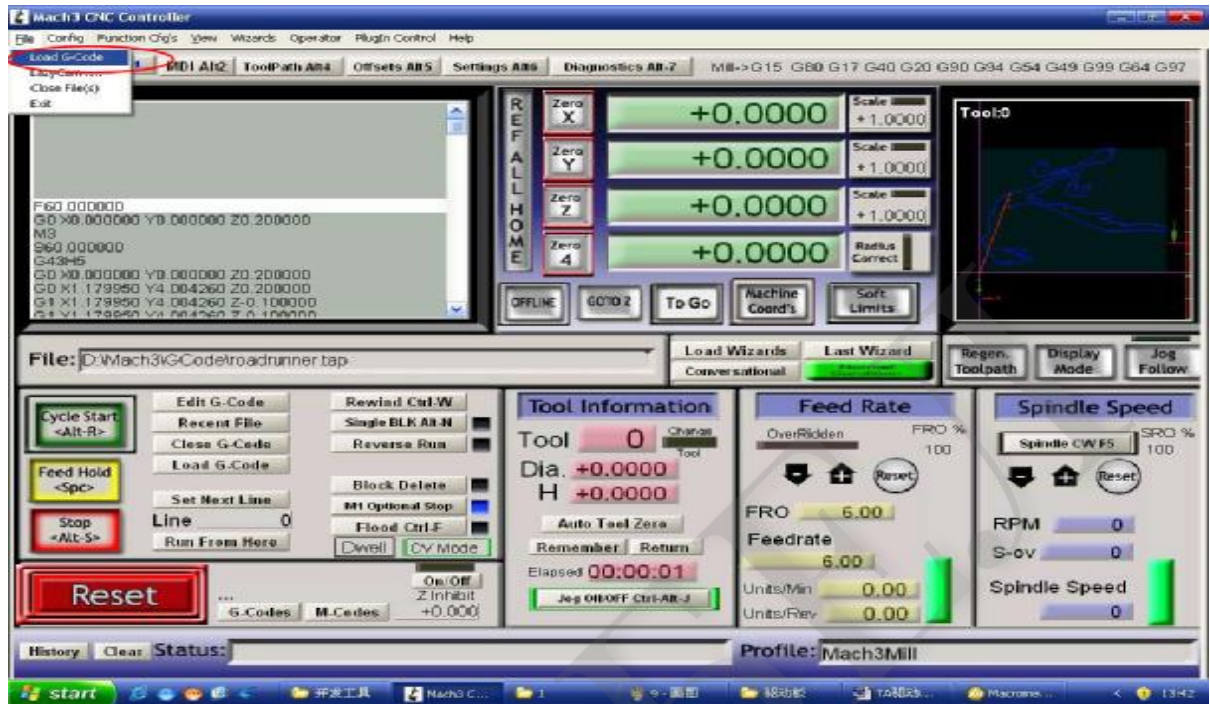

4、Running of G code

G is the numerical instructions control program code , mach3 for customers to test software comes with the G code, you can easily test machine.click the File, as fig 18



Open G code

Click the red circlet **Load G-code** and open the icon  Mach3 and click  GCode ,and choice a G code, the interface as follows as fig 19



Open the testing procedures of G

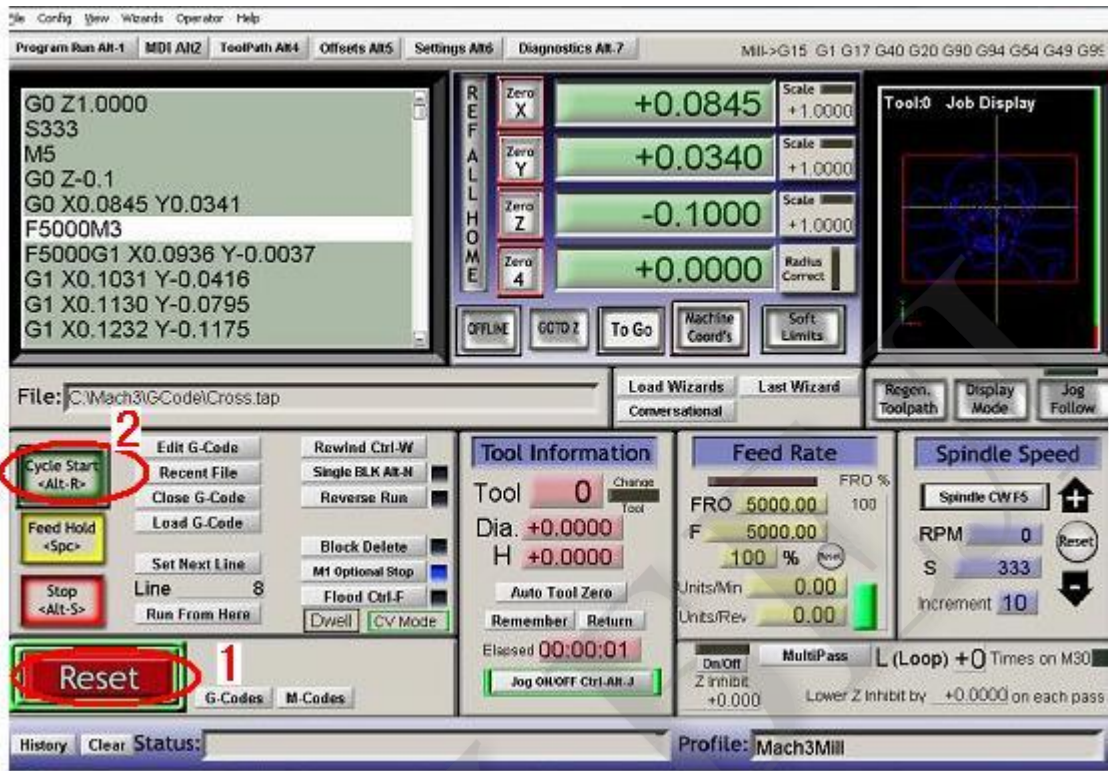

When you open the G code, you may watch on a flashing red button **RESET**, click it to stop, and click the **CYCLESTART**.

If you want to run your own G code for processing, find your location of G code, and leading it in ,

5、 How to use the manual control interface of MACH3

If you want manual control, press the keyboard “TAB” as follows as :

